

BARREL FINISHERS  
**RTS**

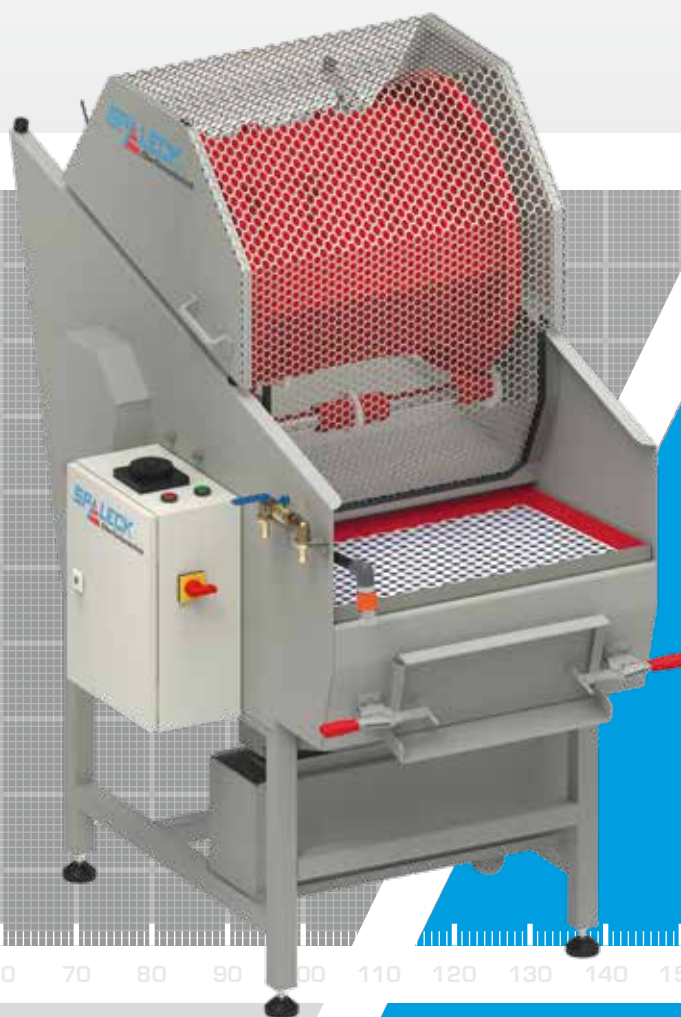

© SPALECK ENGINEERING

RTS

**Deburring • Edge-rounding • Cleaning  
Shining • Polishing • Ball-burnishing**

The barrel surface finishing is the easiest kind of surface finishing and offers, at the same time, most space-saving. Parts, abrasive media and compound are put into a closed drum, that thanks to its rotation sets the mixture into a relative motion. Further, through the parallel use of two drums batch purity can be ensured.

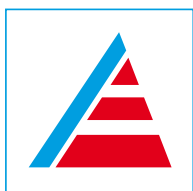

MADE IN GERMANY

[www.spaleck.biz](http://www.spaleck.biz)



# BARREL FINISHERS RTS

## Technical data:

- Basic frame made of stainless steel
- Rinsing unit with manual valve
- Separation unit incl. collecting tank for abrasive media integrated into the machine frame
- Tub lining of wear-resistant polyurethane
- Pivotal protection hood (electrically controlled) to ensure work safety
- Front discharge

## Optional features:

- Selectable different drum sizes
- Simultaneous treatment of different parts by using two drums

## Technical data basic frame:

Description		RTS
Operating voltage	V   Hz	400   50
Drive power	kW	0,75
Empty weight basic frame	kg	150
Space requirement	m <sup>2</sup>	1,2
Motor for drum speed	rpm	ca. 40

## Technical data drums:

Description		RTS1	RTS2	RTS3	RTS4
Drum volume	l	9	15	35	50
Usable volume	l	6	9	25	40
Max. filling weight per drum	kg	30	45	120	180
Max. drum number	pc.	2	2	1	1

## Dimensions basic frame in mm:

Description		RTS
Top edge open basic frame	A	2020
Top edge closed basic frame	B	1530
Top edge separation / collecting tank media	C	780
Bottom edge discharge	D	540
Depth basic frame (open hood)	E	1500
Depth basic frame (closed hood)	F	1260
Width basic frame	G	710
Width basic frame incl. control unit	H	960
Width discharge	I	405

## Dimensions drums in mm:

Description	RTS1	RTS2	RTS3	RTS4
Diameter	330	460	460	530
Width	260	260	530	530
Opening	ca. 137 x 37	ca. 136 x 136	ca. 410 x 135	ca. 410 x 155

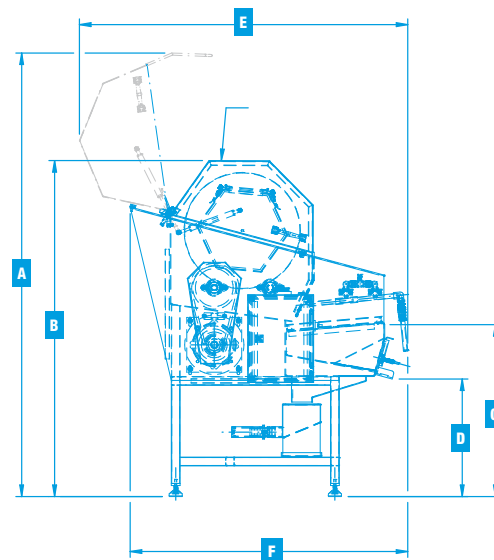
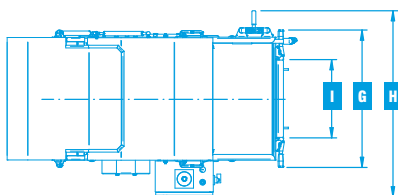

© SPALECK ENGINEERING